

# Chamker®

## air



## AIR/HYDRAULIC RIVETER

MODEL NO: CAT151

PART NO: 3120165

## OPERATING & MAINTENANCE INSTRUCTIONS

UK  
CA | CE

ORIGINAL INSTRUCTIONS

GC0622 Rev 2

---

## **INTRODUCTION**

---

Thank you for purchasing this CLARKE Air Riveter.

The CAT151 Air Riveter is supplied with 4 nose pieces to accept 2.4 mm, 3.2 mm, 4.0 mm and 4.8 mm rivets. The riveter has a hardened steel jaw assembly, a rivet stem safety cap, and is suitable for both aluminium and steel rivets.

Before attempting to use this product, please read this manual thoroughly and follow the instructions carefully. In doing so you will ensure the safety of yourself and that of others around you, and you can look forward to your purchase giving you long and satisfactory service.

---

## **OPERATING PRINCIPLE**

---

The rivet is pushed through the hole in the workpiece and the rivet pin inserted into the rivet gun nosepiece which will grip it tightly.

When the rivet gun is activated the throttle valve allows compressed air through the tool. The pressure of the air forces the rivet pin into the jaws which pull the pin up into the rivet. As the pin is taken up, the base of the rivet expands and this joins the workpiece. The rivet gun pulls the pin until it breaks off, thereby securing the rivet. The used pins are ejected into the safety cap for disposal.

Pop rivets have limited strength so they are typically used for fastening light sheet metals. Professionals sometimes refer to these rivets as blind rivets, as the user cannot see the other side of the material being riveted.

---

## **GUARANTEE**

---

This product is guaranteed against faulty manufacture for a period of 12 months from the date of purchase. Please keep your receipt which will be required as proof of purchase.

This guarantee is invalid if the product is found to have been abused or tampered with in any way, or not used for the purpose for which it was intended.

Faulty goods should be returned to their place of purchase, no product can be returned to us without prior permission.

This guarantee does not effect your statutory rights.

---

# GENERAL SAFETY RULES

---



CAUTION: FAILURE TO FOLLOW THESE PRECAUTIONS COULD RESULT IN PERSONAL INJURY, AND/OR DAMAGE TO PROPERTY.

---

## WORK ENVIRONMENT

1. Keep the work area clean and tidy.
2. Dress appropriately - Do not wear loose clothing or jewellery. Tie long hair out of the way.
3. Keep children and visitors away - Do not let children handle the tool.

## USE

1. Stay alert and use common sense - do not operate this tool when you are tired or under the influence of alcohol, drugs or medication.
2. Always wear eye protectors when using air tools. Eye protectors must provide protection from flying particles from the front and the side.
3. Do not overreach - keep proper footing and balance at all times.
4. Never use oxygen, CO<sub>2</sub>, combustible gasses, or any bottled gas, as a source of power for an air tool. This product should only be used with a suitably rated compressed air supply.
5. Do not connect the air hose with your finger on the trigger of the riveter.
6. Do not fit the air tool to any stand or clamping device that may damage it.
7. Do not exceed the maximum pressure for the tool of 7 bar.
8. Keep the air hose away from heat, oil and sharp edges.
9. Check hoses for leaks or excessive wear before use, and ensure that all connections are secure.
10. Do not use the tool for any other purpose than described in this manual.
11. Do not carry out any alterations or modifications to the tool.
12. Always disconnect from the air supply when:
  - Performing any maintenance.
  - The tool is not in use.
  - The tool will be left unattended.
  - Never use the tool if it is defective or operating abnormally.

13. This air tool should be serviced at regular intervals by qualified service personnel.
14. Avoid damaging the air tool by applying excessive force of any kind.
15. Always maintain the air tool with care. Keep it clean for the best and safest performance.
16. Do not force or misuse the air tool. It will do a better and safer job at the rate for which it was designed.
17. Do not use the riveter if the safety cap is not in place.
18. Do not point the air tool at people or animals.

## **TRANSPORTATION**

1. Never carry an air tool by the air hose.
2. Never carry an air tool with your finger on the trigger.

# OVERVIEW

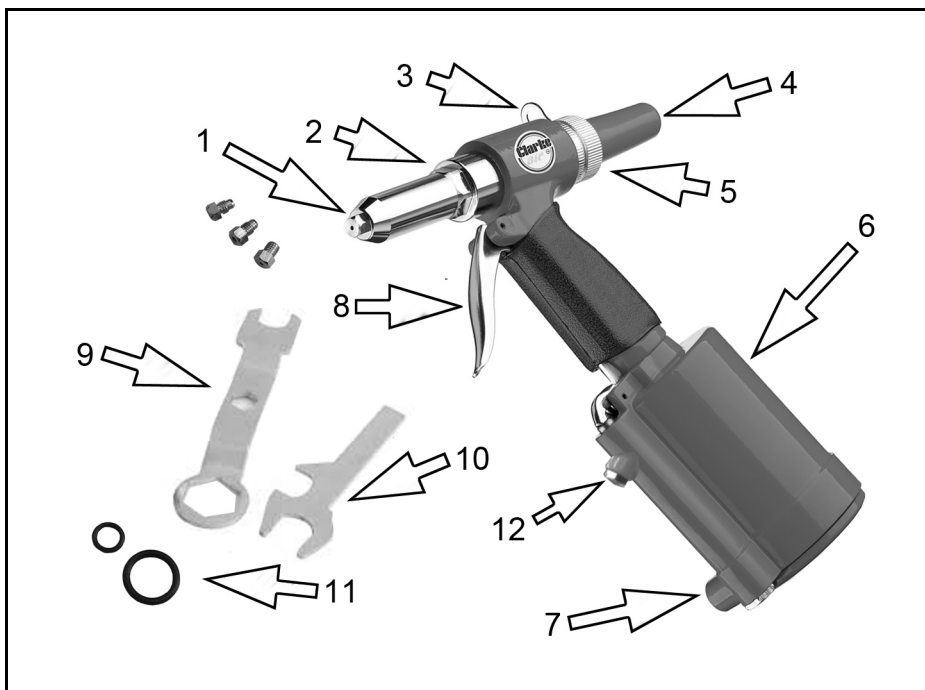

NO	DESCRIPTION	NO	DESCRIPTION
1	Nosepiece (2.4, 3.2, 4.0 & 4.8 dia)	7	1/4" BSP Air Inlet Connection
2	Outer Cylinder	8	Trigger
3	Hanging Ring	9	Spanner
4	Safety Cap	10	Spanner Gauge
5	Retaining ring for safety cap	11	Large and Small O-rings (see p11)
6	Air Cylinder	12	Air Filter

---

## COMPRESSED AIR REQUIREMENTS

---



**WARNING: COMPRESSED AIR CAN BE DANGEROUS. ENSURE THAT YOU ARE FAMILIAR WITH ALL PRECAUTIONS RELATING TO THE USE OF COMPRESSORS AND A COMPRESSED AIR SUPPLY.**

---

- Use only clean, dry, regulated compressed air as a power source.
- Air compressors used with the tool must comply with the appropriate European Community Safety Directives.
- A build-up of moisture or oil in the air compressor will accelerate wear and corrosion in the tool. ensure any moisture is drained from the compressor daily and the inlet filter is kept clean.
- If an unusually long air hose is required, (over 8 metres), the line pressure or the hose inside diameter may need to be increased.
- The air hose must be rated at least 150% of the maximum operating pressure of the tool.

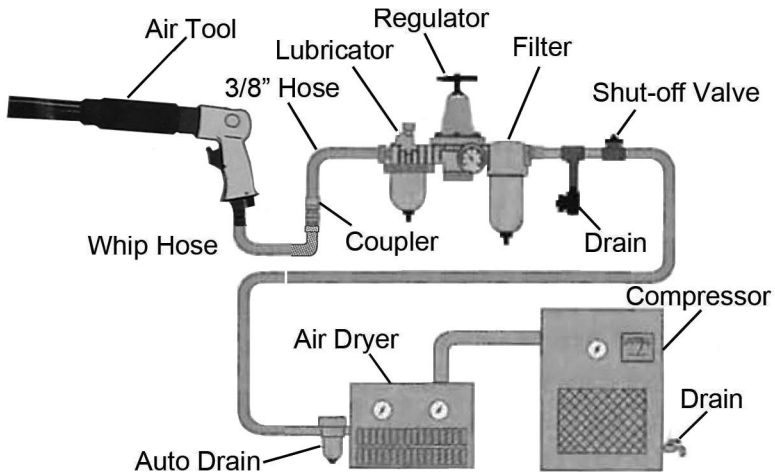

- A typical air line layout is shown above. If an automatic in-line filter/regulator is used, it will keep the tool in good condition, but should be regularly checked & topped up with oil. Clarke air-line oil should be used, and the lubricator adjusted to approx 2 drops per minute.
- Never exceed the maximum operating pressure for the tool. It is recommended that air pressure to this tool does not exceed 7 bar at the tool when running. Higher pressures and unclean air will shorten the life of the tool due to faster wear and is a possible safety hazard.

# PREPARATION & ADJUSTMENT

## FILLING/CHECKING THE OIL LEVEL

Before use, check that the rivet gun is topped up with hydraulic oil (not supplied) after removing the cylinder cap and piston assembly to ensure that it is properly lubricated.

1. Disconnect the riveter from the air line.
2. Hold upside-down and remove the air cylinder cap (fig 1) with the spanner provided.
3. Remove the air/hydraulic piston assembly (grip the exposed nut and pull up) as in Fig 2.
4. Add hydraulic oil to the hydraulic cylinder until the level is just below the connection with the air cylinder. See fig. 3.
  - Hydraulic oil is available from your Clarke dealer: part No 3050830 (1 litre).
5. Lightly lubricate the inner wall of the air cylinder.
6. Replace the air/hydraulic piston assembly and press in as far as it will go.
7. Refit and tighten the air cylinder cap.

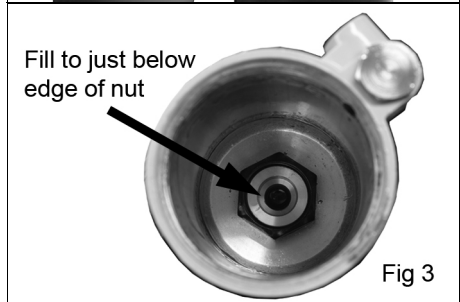
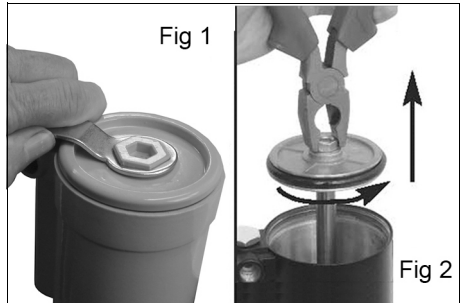

## CHECKING/ADJUSTING THE STROKE

1. Check that the hydraulic oil level is correct as above.
2. Remove the outer cylinder using the spanner provided.

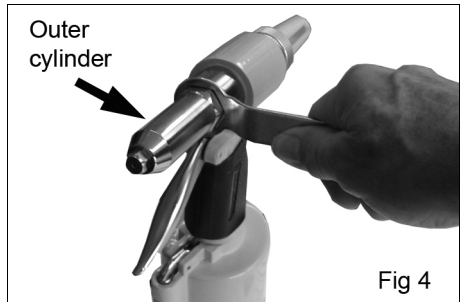

3. Check the jaw stroke by using the spanner/gauge as in figs 5 and 6.
4. Set the distance to < 70 mm i.e. the length of the spanner gauge as shown.

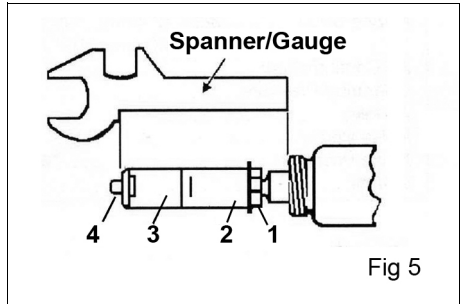

5. If necessary, adjust the stroke as follows:
  - Hold the rear jaw case (fig 7) with the larger spanner and loosen the lock nut with the spanner/gauge.
  - Adjust the stroke by rotating the jaw case assembly and tightening the lock nut when adjustment is complete.
6. Refit the outer cylinder.

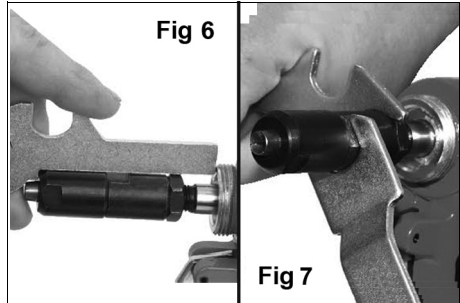

## CONNECTING THE AIRLINE

**NOTE:** Ensure the air compressor is turned off.

1. Remove the protective plug from the air inlet port and connect a suitable hose as shown.
2. Connect the other end of the hose to the compressor.
3. Turn on the air supply and check for air leaks. Rectify any leaks found before proceeding.
  - PTFE tape may be helpful for sealing threaded connections.
4. If required, connect an in-line mini oiler into the air supply line to the tool.
  - A mini oiler helps to prolong the life of the air tool.
  - If a mini-oiler is not being used, run a few drops of oil through the tool before use. It can be entered through the inlet connector or via the hose at the nearest connection to the air supply.

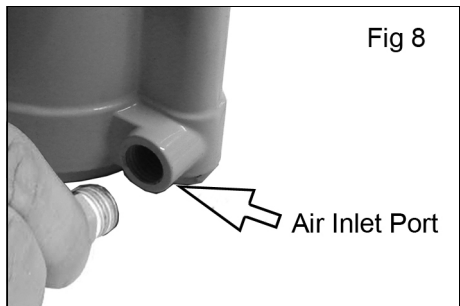



5. Turn the compressor back on and set the regulator to 6.3 to 7 bar. Do not exceed this pressure.
6. Your air riveter is now ready for use.
  - You can fit a whip hose with a quick fit coupling if required (available from your Clarke dealer).

---

## OPERATION

---



**WARNING: ALWAYS FIT THE SAFETY CAP TO THE REAR OF THE FRAME BEFORE USE TO PREVENT INJURY FROM EJECTED RIVET STEMS. FIT WITH THE SLOT FACING DOWNWARDS SO THAT THE STEMS FALL TO THE FLOOR.**

---

1. Select the nosepiece to suit the rivet size and fit it to the head using the spanner.
2. Insert the rivet stem fully through the nosepiece and into the jaws.
3. Press the rivet body through the pre-drilled hole in the workpiece and hold the rivet flange flush against the workpiece. Always take care to drill the holes with the same size drill bit as the rivets to be used.
4. Squeeze the trigger.
  - The rivet will be compressed and the rivet stem will be ejected into the safety cap from where they can be collected for disposal.

## DISCONNECTING THE AIR SUPPLY

1. Do not disconnect the air supply hose until the compressor has been shut down and the compressed air released.
2. Squeeze the trigger to discharge any compressed air from the riveter.
3. Once the pressure has been released, disconnect the air supply hose from the air tool.
4. Store the tool safely in its box in a dry, secure environment.

---

# MAINTENANCE

---



**WARNING: MAKE SURE THAT THE AIR TOOL IS DISCONNECTED FROM THE AIR SUPPLY BEFORE STARTING ANY CLEANING OR MAINTENANCE PROCEDURES.**

---

## DAILY

1. Before use, drain water from the air-line and compressor.
2. Maintain the tool with care. Keep it oiled for optimum performance.
3. Lubricate the air tool daily with a high quality air tool oil either via an oiler in the air supply system or by placing a few drops into the riveter air inlet immediately before use. This should be carried out regardless of whether or not an in-line mini oiler is used. If an in-line mini oiler is not used, this procedure should be repeated after every two hours of constant use.

## CLEANING

1. Keep the tool clean.
2. Deposits in the tool may also reduce efficiency. This can be corrected by cleaning the air inlet and flushing out the tool with gum solvent oil, or failing this, the tool should be disassembled, thoroughly cleaned, dried and reassembled.
3. If the tool becomes inefficient and the air supply is of good quality, it may be necessary to replace worn or damaged parts. You may prefer to take the tool to your Clarke dealer if internal maintenance is required.

## CHANGING JAWS

1. Disconnect the tool from the air line.
2. Remove the outer cylinder (fig 9) using the spanner provided.
3. Use both spanners to unscrew the front jaw case (fig 10) from the rear jaw case.
4. Remove the jaws and clean with solvent and brush. If the teeth are blunted, replace with new jaws.

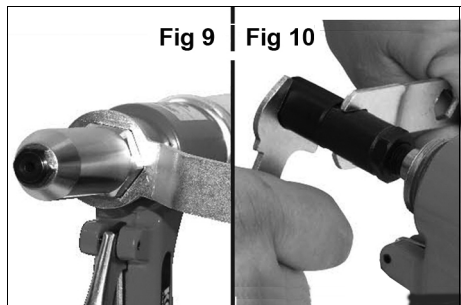

Reverse the above procedure to reassemble.

## OTHER REPLACEMENT PARTS

The CAT151 is supplied with two replacement O-rings shown as items 15 and 24/25 on the parts list and diagram. Suitable spanners will be required to disassemble the riveter. If difficulty is found take the riveter to your Clarke dealer for this operation.

## PERFORMANCE

Please note that factors other than the tool may effect its operation and efficiency such as reduced compressor output, excessive drain on the airline, moisture or restrictions in the air-line, or the use of connectors of improper size or poor condition which will reduce air supply.

Clarke Air-Line Oil (Part no. 3050825) is available from your Clarke dealer.

Your Clarke air tool has been designed to give long and trouble free service. If, however, having followed the instructions in this booklet carefully, you encounter problems, take the tool to your local Clarke dealer.

## STORAGE

If the tool is to be stored, or is idle for longer than 24 hours, run a few drops of Clarke air-line oil into the air inlet, and depress the trigger in order to lubricate the internal parts.

When not in use, the tool must be disconnected from the air supply and stored in a dry place out of the reach of children.

Avoid storing in cold or damp environments.

## ACCESSORIES AND CONSUMABLES

A wide range of airline accessories is available including filter/regulators, lubricators, high-pressure hoses (5 to 50 metres) etc. Contact your Clarke dealer or Clarke International Service Department for further information.

Rivets are available for the CAT151 in the following sizes.

Rivet Size (Pack of 100)	Clarke Part No
3.2 x 6.0mm	3111770
3.2 x 10.2mm	3111775
3.2 x 16.5mm	3111780
4.0 x 6.4mm	3111785
4.0 x 11.0mm	3111790
4.0 x 16.0mm	3111795
4.8 x 6.4mm	3111800
4.8 x 9.6mm	3111805
4.8 x 16.0mm	3111810

---

## SPECIFICATION

---

<b>Model Numbers</b>	<b>CAT151</b>
Rivet Capacity	2.4, 3.2, 4.0 & 4.8 mm dia
Operating Pressure	6.3 bar
Maximum Operating Pressure	7 bar
Air Consumption	0.03 cfm average
Traction Power	720 kg
Air Inlet Size	1/4" BSP female thread
Vibration Levels	2.45 m/s <sup>2</sup>
Uncertainty Factor (K)	1.5
Sound Power Level	97 dB LWA
Sound Pressure Level	86 dBA
Uncertainty Factor (K)	3.0
Dimensions (L x D x H)	230 x 81 x 290 mm
Weight	1.9 kg

Please note that the details and specifications contained herein are correct at the time of going to print. However Clarke International reserve the right to change specifications at any time without prior notice.

# DECLARATIONS OF CONFORMITY



**Clarke®**  
**INTERNATIONAL**  
Fitzwilliam Hall, Fitzwilliam Place, Dublin 2

## DECLARATION OF CONFORMITY

This is an important document and should be retained.

We hereby declare that this product(s) complies with the following directive(s):  
2006/42/EC Machinery Directive

The following standards have been applied to the product(s):

EN ISO 11148-1:2011

The technical documentation required to demonstrate that the product(s) meet(s) the requirement(s) of the aforementioned directive(s) has been compiled and is available for inspection by the relevant enforcement authorities.

The CE mark was first applied in: 2012

**Product Description:** Air Riveter  
**Model number(s):** CAT151  
**Serial / batch Number:** N/A  
**Date of issue:** 07/06/2022

Signed:

J.A. Clarke  
Director

CAT151 CE Clarke DDC 06/022

Page 1 of 1



**Clarke®**  
**INTERNATIONAL**  
Hemmill Street, Epping, Essex, CM16 4LG

## DECLARATION OF CONFORMITY

This is an important document and should be retained.

We hereby declare that this product(s) complies with the following statutory requirement(s):  
Supply of Machinery (Safety) Regulations 2008

The following standards have been applied to the product(s):

EN ISO 11148-1:2011

The technical documentation required to demonstrate that the product(s) meet(s) the requirement(s) of the aforementioned legislation has been compiled and is available for inspection by the relevant enforcement authorities.

The UKCA mark was first applied in: 2022

**Product Description:** Air Riveter  
**Model number(s):** CAT151  
**Serial / batch Number:** N/A  
**Date of issue:** 07/06/2022

Signed:

J.A. Clarke  
Director

CATH UKCA Clarke DDC 06/022

Page 1 of 1

## PARTS LIST

No	Description
1A	Nosepiece (4.8mm - 3/16")
1B	Nosepiece (4mm - 5/32")
1C	Nosepiece (3.2mm - 1/8")
1D	Nosepiece (2.4mm - 3/32")
2	Socket head
3	Jaw Case
4	Jaw Case Joint
5	Jaws
6	Jaw Pusher
7	Jaw Pusher Spring
8	Jaw Case Washer Ring
9	Jaw Case Lock Nut
10	O-ring
11	O-ring
12	Back-up ring
13	Housing
14	Oil Piston
15	Oil Piston O-ring
16	Oil Piston Back-up Ring
17	Return Spring A
18	Return Spring B
19	Hanging Ring
20	Housing Cap
21	Safety Cap
22	Housing Cap Nut
23	Spacer
24	U-type ring
25	O-Ring

No	Description
26	Bush
27	Trigger
28	Trigger Pin
29	Rod Pin
30	Trigger Rod
31	Trigger Lever
32	Rod Pin
33	Lever Pin
34	Air Cylinder
35	Valve Pusher O-Ring
36	Brass Valve Pusher
37	Valve Pusher Spring
38	Valve Pusher Brass Collar
39	Valve Pusher O-Ring
40	Valve
41	Valve Spring
42	Valve cap O-Ring
43	Valve cap
44	Frame Lock Nut
45	Air Piston Stem
46	Rubber Cushion
47	Air Piston O-Ring
48	Air Piston
49	Air Piston Locknut
50	Air Cylinder O-Ring
51	Air Cylinder cap
52	Spanner Gauge (17/14 mm)
53	Spanner (10/15/24 mm)

# PARTS DIAGRAM

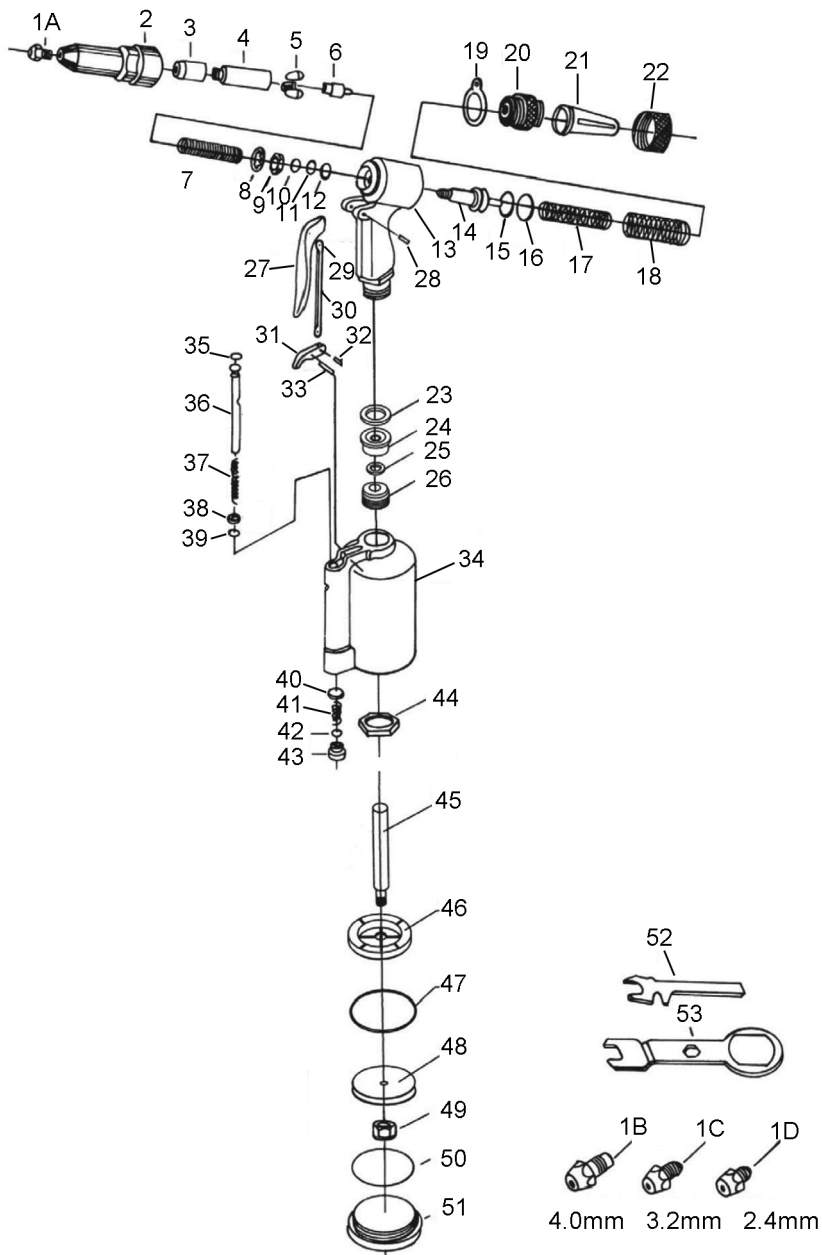

# A SELECTION FROM THE VAST RANGE OF

# Clarke®

## QUALITY PRODUCTS



### **AIR COMPRESSORS**

From DIY to industrial, Plus air tools, spray guns and accessories.

### **GENERATORS**

Prime duty or emergency standby for business, home and leisure.

### **POWER WASHERS**

Hot and cold, electric and engine driven - we have what you need

### **WELDERS**

Mig, Arc, Tig and Spot. From DIY to auto/industrial.

### **METALWORKING**

Drills, grinders and saws for DIY and professional use.

### **WOODWORKING**

Saws, sanders, lathes, mortisers and dust extraction.

### **HYDRAULICS**

Cranes, body repair kits, transmission jacks for all types of workshop use.

### **WATER PUMPS**

Submersible, electric and engine driven for DIY, agriculture and industry.

### **POWER TOOLS**

Angle grinders, cordless drill sets, saws and sanders.

### **STARTERS/CHARGERS**

All sizes for car and commercial use.

## **PARTS & SERVICE: 0208 988 7400**

**Parts Enquiries**  
[Parts@clarkeinternational.com](mailto:Parts@clarkeinternational.com)

**Servicing & Technical Enquiries**  
[Service@clarkeinternational.com](mailto:Service@clarkeinternational.com)

SALES: UK 01992 565333 or Export 00 44 (0)1992 565335

**Clarke** INTERNATIONAL Hemnall Street, Epping, Essex CM16 4LG  
[www.clarkeinternational.com](http://www.clarkeinternational.com)